

# CNDR DRUM BLAST

Loading

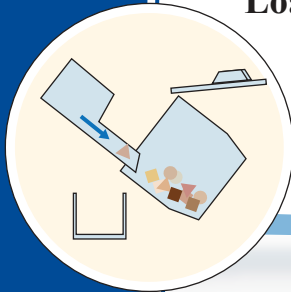

Agitating and  
Cleaning

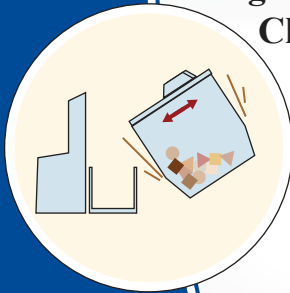

Unloading

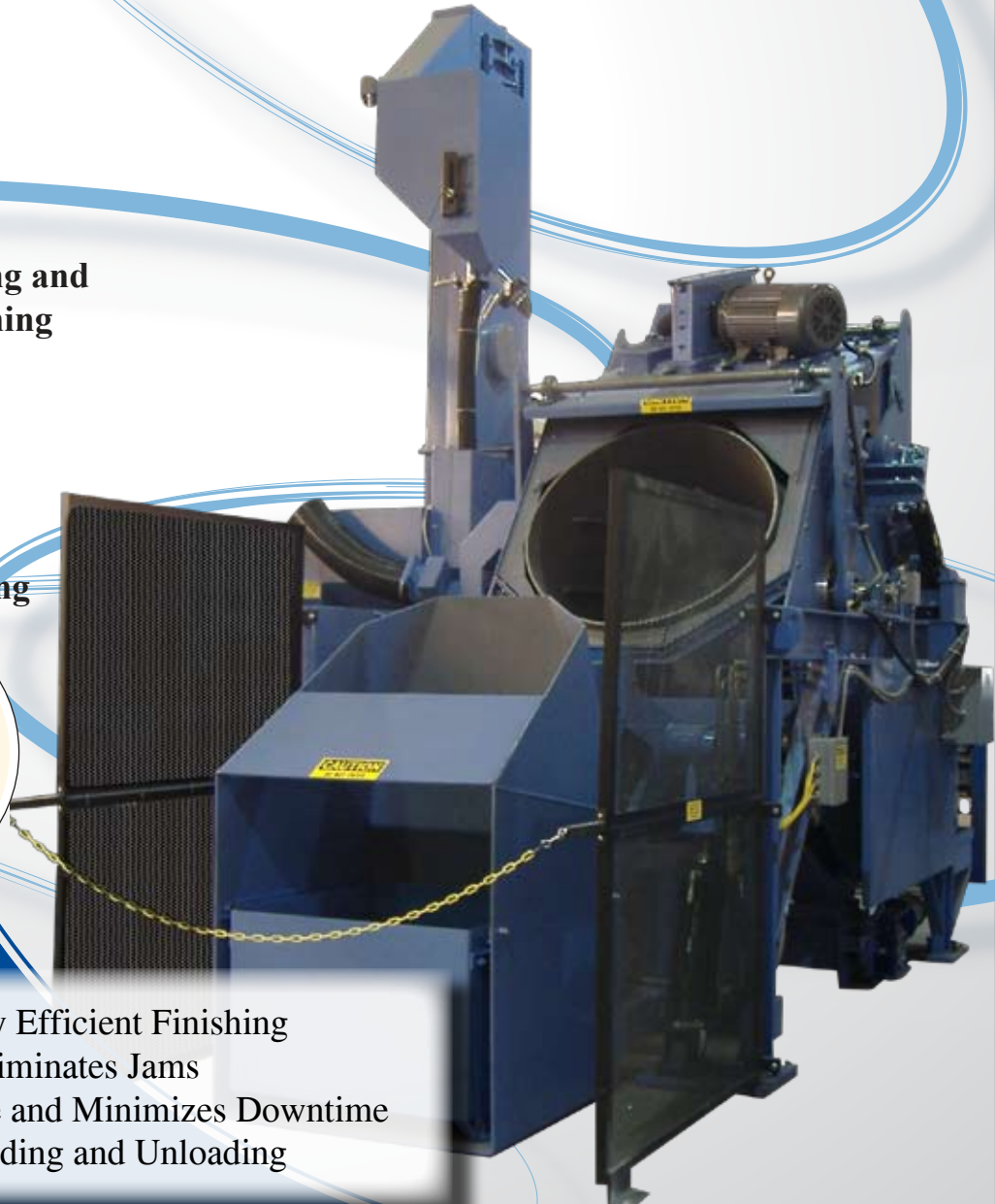
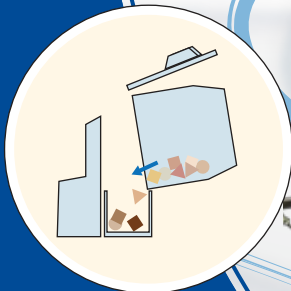

- Consistent and Highly Efficient Finishing
- Zero Pinch Design Eliminates Jams
- Reduces Maintenance and Minimizes Downtime
- Smooth, Reliable Loading and Unloading



# SST

SURFACE TREATMENT

A Division of Roberts Sinto Corporation

3001 West Main St • PO Box 40760

Lansing, MI 48901-7960

Toll Free: 800-748-0384 • Tel: 517-371-2460

[www.RobertsSinto.com](http://www.RobertsSinto.com)

# CNDR DRUM BLAST



Hydraulic  
Loader



Floor  
Mounted  
Separator



Machine Description	6 cuft.	10 cuft.	14cuft.	22cuft.
Width (A)	8'- 10"	10'- 8"	10'- 8"	12'- 6"
Depth (B)	10'-10"	16'-9"	16'- 9"	17'- 11"
Height (C)	14'-0"	17'-5"	18'- 7"	20'- 10"
Work Disc. (D)	20"	35"	59"	53"
Volume	5.3 cuft./load	10.6 cuft./load	14.1 cuft./load	21.2 cuft./load
Charge Weight	660 lbs/load	1320 lbs/load	1750 lbs/load	2650 lbs/load
Max. Part Weight	22lbs	77lbs	80lbs	90lbs
Max. Part Dimension	12"	16"	16"	22"
Motor HP	20hp	30hp	40hp	60hp
Abrasive Flow Rate	485lbs/min	790lbs/min	790lbs/min	1015lbs/min
DC - Descaling	1650cfm	1750cfm	1750cfm	3000cfm
DC - Sand Removal	2500cfm	2650cfm	2650cfm	3500cfm
Device	Bucket	Bucket	Bucket	Bucket
Temp.	176 degrees F	176 degrees F	176 degrees F	176 degrees F

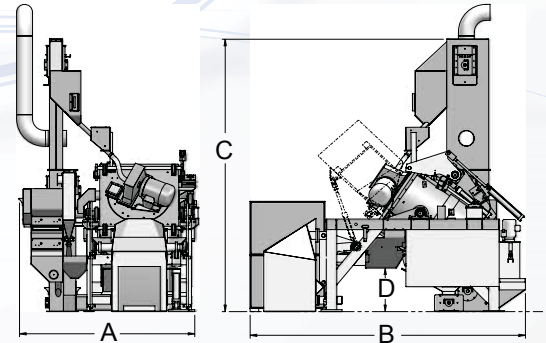

## Features

- Less parts maintenance than conventional tumblast machines
- Faster blasting cycle due to improved direct drive wheel
- Floor mounted separating unit for easy monitoring of abrasive cleaning
- Faster overall cycle time
- No leak drum design



**SST**  
SURFACE TREATMENT

A Division of Roberts Sinto Corporation

3001 West Main St • PO Box 40760

Lansing, MI 48901-7960

Toll Free: 800-748-0384 • Tel: 517-371-2460

www.RobertsSinto.com