

KSB MONORAIL SPINNER HANGER EQUIPMENT

Benefits:

- Easily handles heavy work pieces
- Complicated weldments and castings
- No part on part contact
- No blind shot angles (rotation and traversing of parts in blast)



SSST

SURFACE TREATMENT

A Division of Roberts Sinto Corporation

3001 West Main St • PO Box 40760

Lansing, MI 48901-7960

Toll Free: 800-748-0384 • Tel: 517-371-2460

www.RobertsSinto.com

**KSB MONORAIL
SPINNER HANGER
EQUIPMENT**

Freedom of Layout to Maximize Efficiency

• Reciprocating type
(standard type)

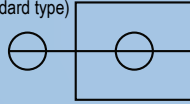

• Through type

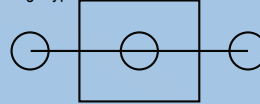

• Loop type

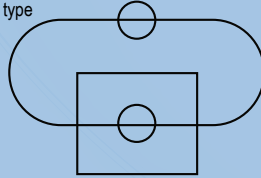

• Y type

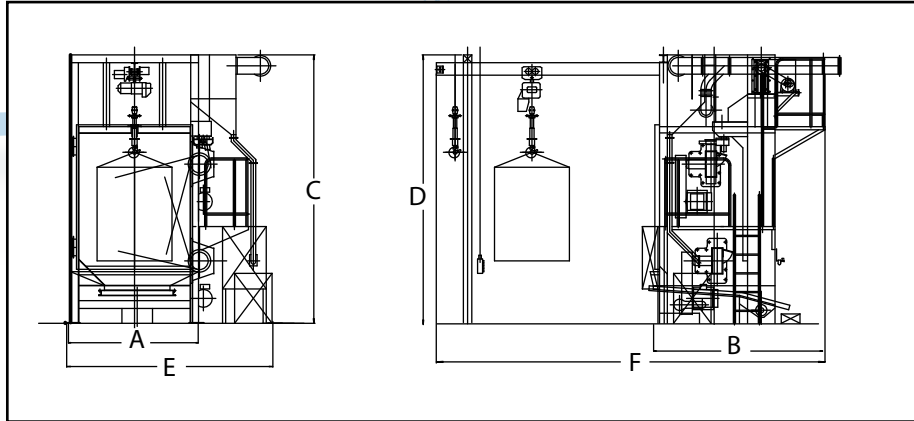
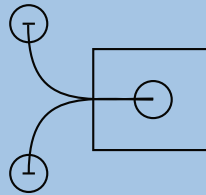

Machine Description		KSB-10	KSB-25	KSB-25A	KSB-50
Cleaning Capacity	Max. Work Size (dia. x H)	47" x 59"	59" x 78"	78" x 98"	98" x 118"
	Max. Hanger Load (Ton)	1	2.5	2.5	5
Blast Wheel	Model	Y-30	Y-30	Y-30	Y-30
	Qty x Hp	2 x 15	3 x 15	4 x 15	5 x 15
Required Ventilation (CFM)		1800	2700	3600	5300
Machine Dimensions	A	5'11"	6'11"	9'5"	10'10"
	B	6'1"	6'11"	7'11"	10'3"
	C	14'2"	18'0"	19'7"	23'6"
	D	14'10"	18'9"	21'0"	25'0"
	E	9'11"	11'6"	13'3"	16'0"
	F	17'10"	19'4"	23'0"	29'5"

Specifications subject to change without notice



SST
SURFACE TREATMENT

A Division of Roberts Sinto Corporation
3001 West Main St • PO Box 40760
Lansing, MI 48901-7960
Toll Free: 800-748-0384 • Tel: 517-371-2460
www.RobertsSinto.com