

# RUBBERBELT TUMBLE BLAST EQUIPMENT

COYOTE DESIGN,  
MANUFACTURED BY  
ROBERTS SINTO CORP.

- Direct Drive Blast Wheel
- 3 Phase Operation
- Continuous Molded Rubber Belt
- Low Noise Level
- Safety Interlocks
- Reversing Mill
- Automatic Timer Controls
- Machine Warranty
- Lip Separator



A Division of Roberts Sinto Corporation



SINTO SURFACE TREATMENT

phone: 517-371-2460 • e-mail: info@robertssinto.com • www.robertssinto.com

## Tumble blast Benefits

### Blast Wheel

Direct Drive bi-directional wheel revolves at 3600 RPM for maximum abrasive velocity. Housing is lined with cast abrasion resistant liners that are replaceable.

### Cabinet

Low profile, formed from 3/8" steel plate to maintain structural integrity. Access holes in sides and front simplify belt replacement and removal of tramp metal collected on abrasive screen.

### Door

Pneumatically operated reinforced rubber door opens and closes easily and provides full access to blast chamber. Door is positively sealed from abrasive and dust leakage.

### Conveyor

Continuous molded rubber tumble belt is 4-ply construction with 1/4" abrasive drain holes. Rubber tumbling ridges are molded directly onto the belt. Screw adjusted take-ups provide positive belt adjustment.

### Abrasive Recycling System

Centrifugal discharge belt and bucket elevator is dust-tight. Removable cover permits service and inspection. The gravity lip separator continuously eliminates light contaminants. Abrasive screening in cabinet eliminates tramp metal from entering blast wheel.

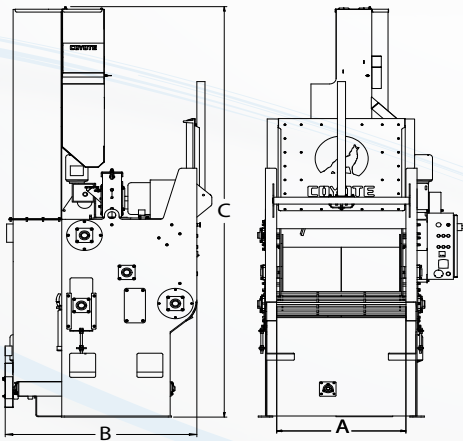

Machine Description	1.5 Cu. Ft.	3 Cu. Ft.	6 Cu. Ft.
Width (A)	28"	52"	61"
Depth (B)	44"	56"	66"
Height (C)	79.5"	8' 0"	12' 8"
Workload Capacity (Lbs)	150 Lbs.	400 Lbs.	800 Lbs.
Workload Dimensions	17" x 20" Dia.	31" x 24" Dia.	37" x 27.5" Dia.
Required Ventilation (CFM)	400 CFM	600 CFM	800 CFM
Shipping Weight	1300 Lbs.	2500 Lbs.	4000 Lbs.
Abrasive Wheel	3 HP @ 3600 RPM	10 HP @ 3600 RPM	15 HP @ 3600 RPM
Abrasive Initial Filling	100 Lbs.	400 Lbs.	500 Lbs.
Noise Level (Approx.)	80 dBa	80 dBa	80 dBa

A Division of Roberts Sinto Corporation



SINTO SURFACE TREATMENT

phone: 517-371-2460 • e-mail: info@robertssinto.com • www.robertssinto.com