

SPINNER HANGER EQUIPMENT

COYOTE DESIGN,
MANUFACTURED BY
ROBERTS SINTO CORP.

Benefits:

- Low Cycle Times
- Compact Design
- No Part on Part Contact
- Single Operator
- Superior Cleaning Efficiency
- Chemical Free Process

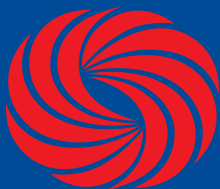

SST

SURFACE TREATMENT

sinto

A Division of Roberts Sinto Corporation

3001 West Main St • PO Box 40760

Lansing, MI 48901-7960

Toll Free: 800-748-0384 • Tel: 517-371-2460

www.SintoBlast.com

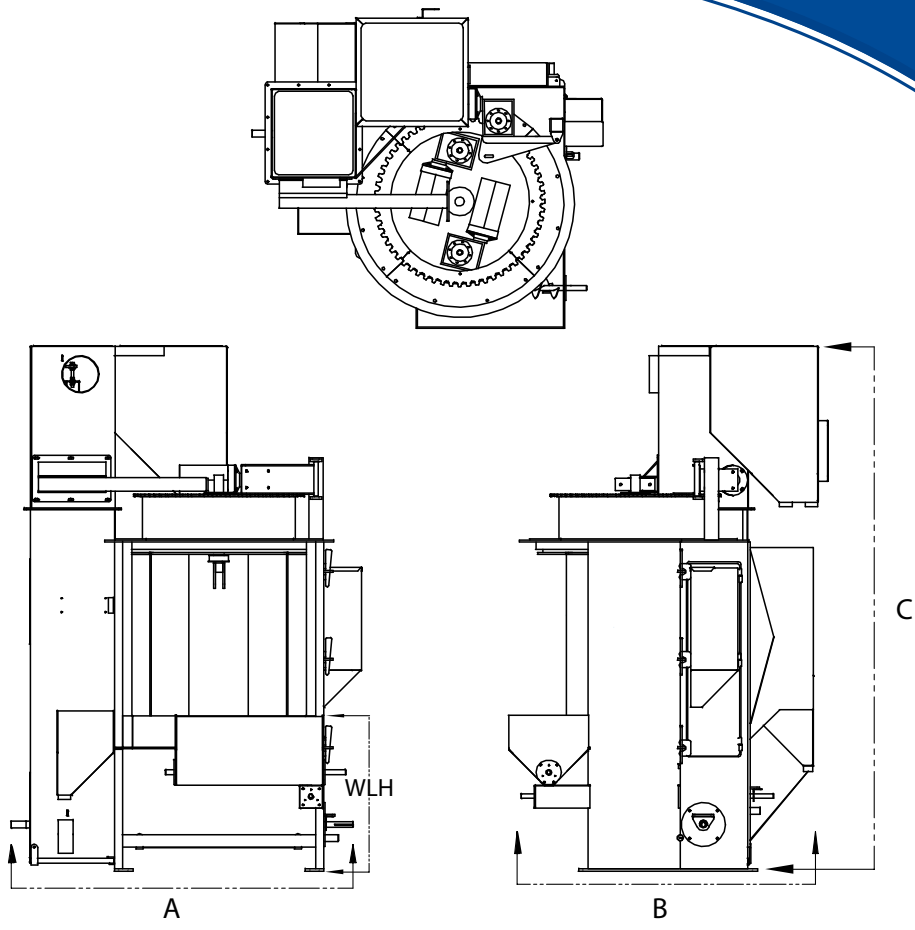

| Machine Description | 2460 | 3072 | 3684 | 4884 |
|-------------------------------|-------------------------|-------------------------|-------------------------|-------------------------|
| Width (A) | 7'1" | 12'8" | 12'4" | 15'8" |
| Depth (B) | 6'6" | 8' 1.25" | 8'8" | 11' |
| Height (C) | 9'10" | 12' 10.25" | 15'6" | 16'8" |
| Workload Dimensions | 24" dia. x 60" vertical | 30" dia. x 72" vertical | 36" dia. x 84" vertical | 48" dia. x 84" vertical |
| Number of Wheels | 2 | 2 or 4 | 4 | 4 |
| Blast Wheel hp | 10 hp ea. | 15 hp ea. | 20 hp ea. | 20 hp ea. |
| Work Loading Height (WLH) | 2'2" | 2'4" | 2'8" | 3'8" |
| Cleaning Envelope Size | 24" dia. x 48" vertical | *See Note (A) | 36" dia. x 66" vertical | 48" dia. x 66" vertical |
| Workload Capacity (lbs) | 800 | 2500 | 2500 | 2500 |
| Required Ventilation (CFM) | 2000 | 2000 | 2000 | 2500 |
| Shipping Weight (lbs) | 8,000 | 13,500 | 15,000 | 16,000 |
| Initial Abrasive Charge (lbs) | 1,500 | 2,000 | 3,000 | 3,000 |
| Noise Level (Approx. dBa) | 85 | 85 | 85 | 85 |

Note: (A) 30" dia. x 48" vertical / 30" dia. x 54" vertical
 (This is meant to signify 2 wheels / 4 wheels)



SST

SURFACE TREATMENT

A Division of Roberts Sinto Corporation
 3001 West Main St • PO Box 40760
 Lansing, MI 48901-7960
 Toll Free: 800-748-0384 • Tel: 517-371-2460
www.SintoBlast.com